

Utilisation de

CREER  
UN COMPOSANT

# SKETCHUP

## MODELEUR VOLUMIQUE

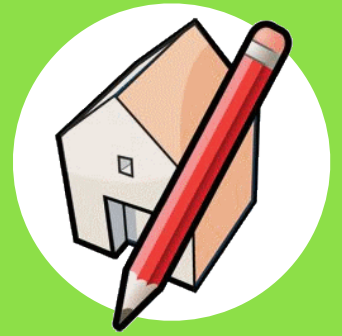

### CRÉER UN COMPOSANT

1

Ouvrir le volume  
**Fichier > Ouvrir**

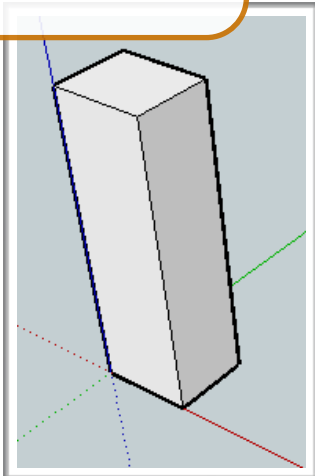

2

Sélectionner  
toute la pièce

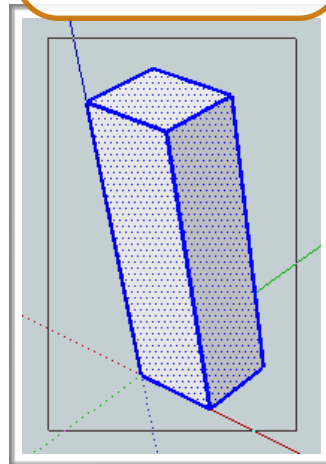

3

**Edition >  
Créer un  
composant**

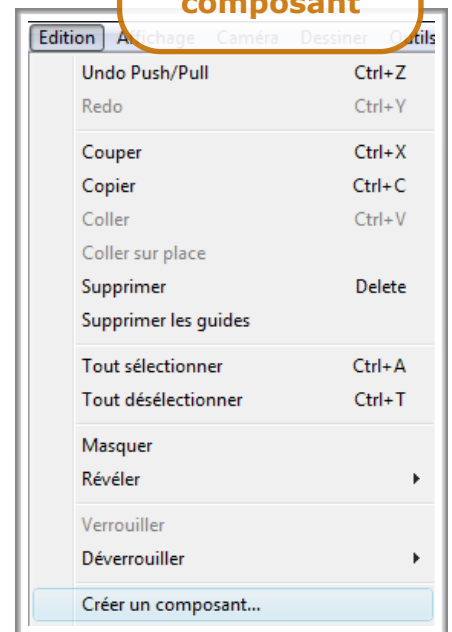

4

**Donner un nom  
au  
composant > Créer**

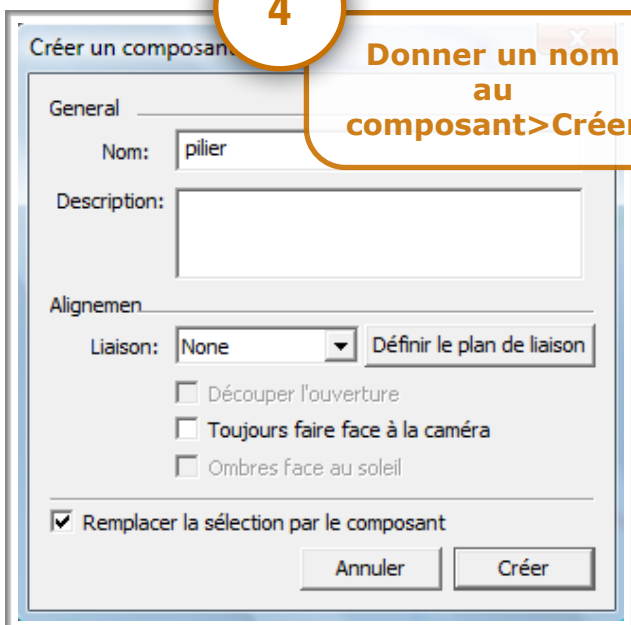

**C'est  
terminé !...Pensez  
à sauvegarder !**

